

LOAD PERFORMANCE CURVE

Three Phase Induction Motor - Squirrel Cage



Customer : _____

Product line : General High Efficiency Three-Phase Product code : 11996114

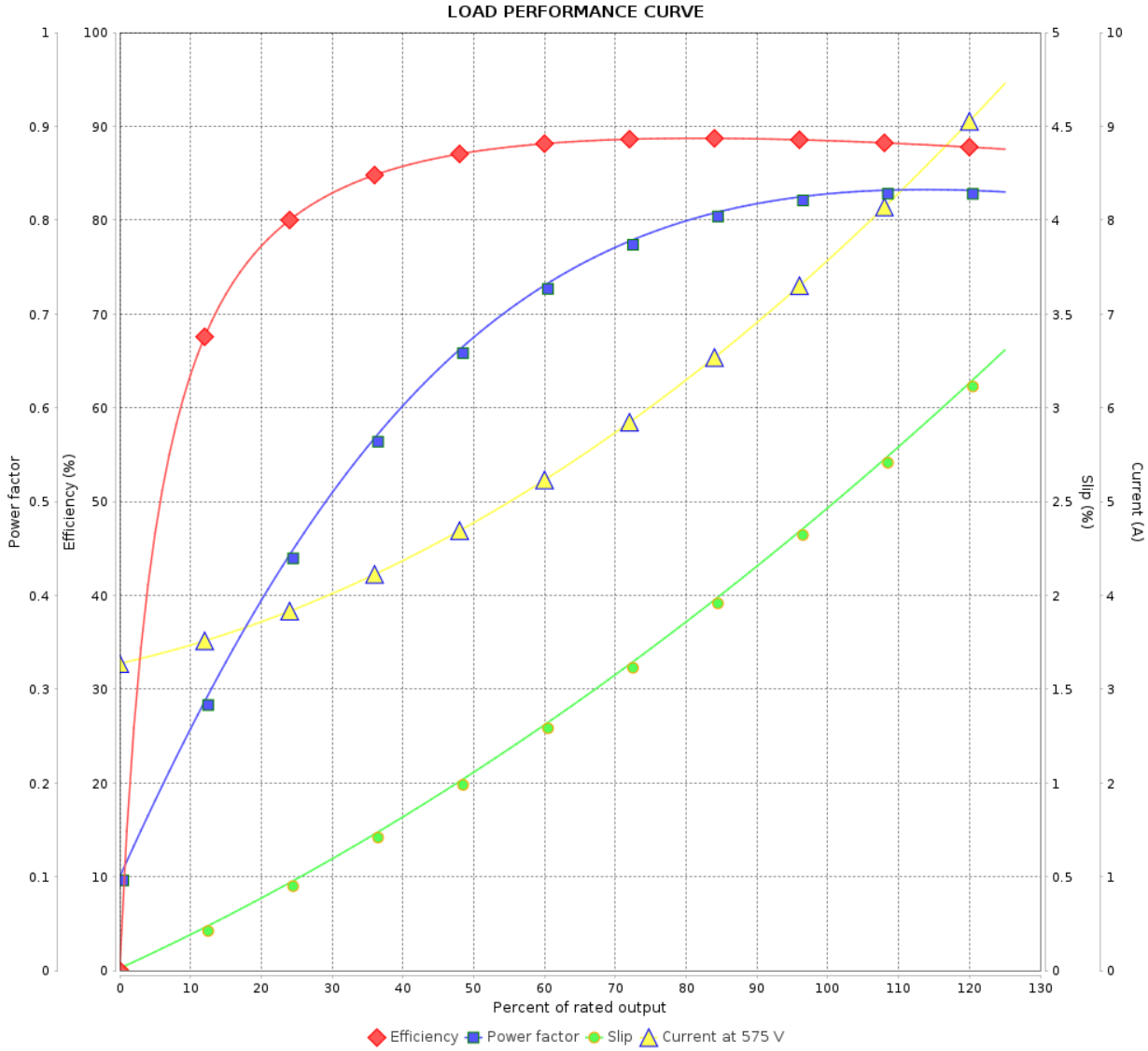

Rev.	Changes Summary	Performed	Checked	Date
Performed by		Page		Revision
Checked by		2 / 2		
Date		12/05/2026		

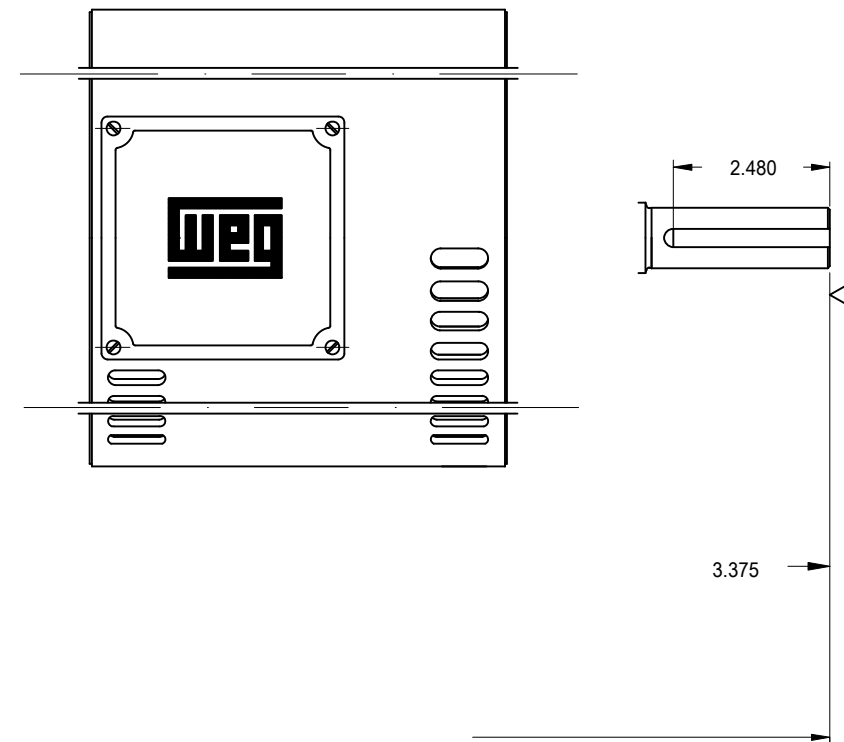
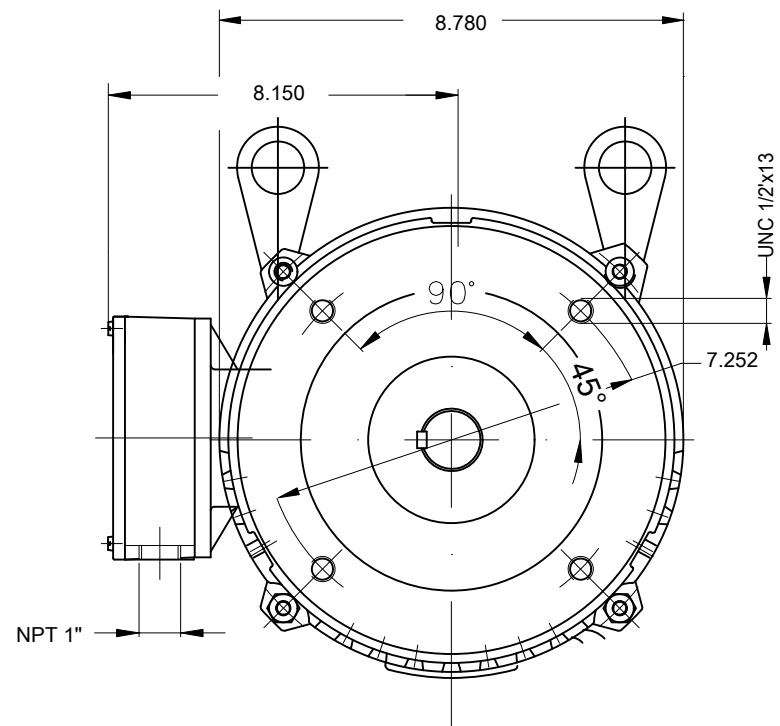

A
B
C

D

E

- Packing - crate
- Plastic flat plug
- With drip cover
- Color RAL 5009
- Painting plan 207A
- Mounting V18

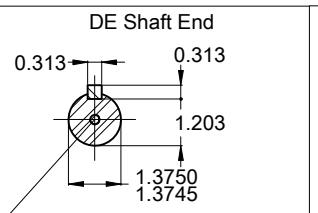

7.5 HP 04 Poles 60 Hz A

						HYBRISUSER								00		
ECM	LOC	SUMMARY OF MODIFICATIONS				EXECUTED	CHECKED	RELEASED	DATE	VER						
EXECUTED	HYBRISUSER	THREE PH. MOTOR GENERAL HIGH EFF. FRAME 213/5TC IP21 ODP				PREVIEW WDD 00										
CHECKED																
RELEASED																
REL. DATE		WMO	Jaragua do Sul	Product Engineering	SHEET	1 / 1										