

LOAD PERFORMANCE CURVE

Three Phase Induction Motor - Squirrel Cage



Customer : _____

Product line : General High Efficiency Three-Phase Product code : 11996330

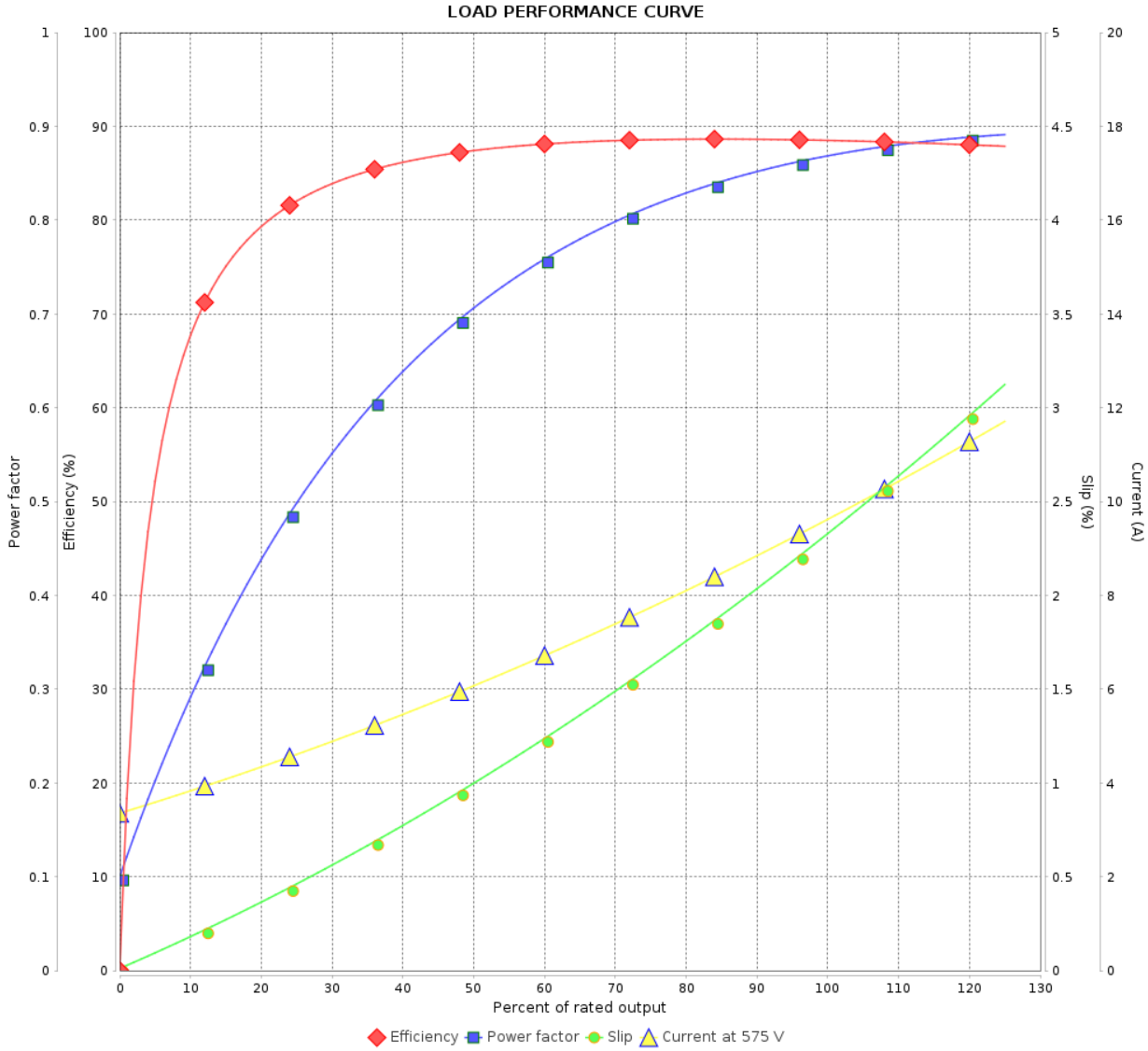

Rev.	Changes Summary	Performed	Checked	Date
Performed by		Page 2 / 2		Revision
Checked by				
Date				

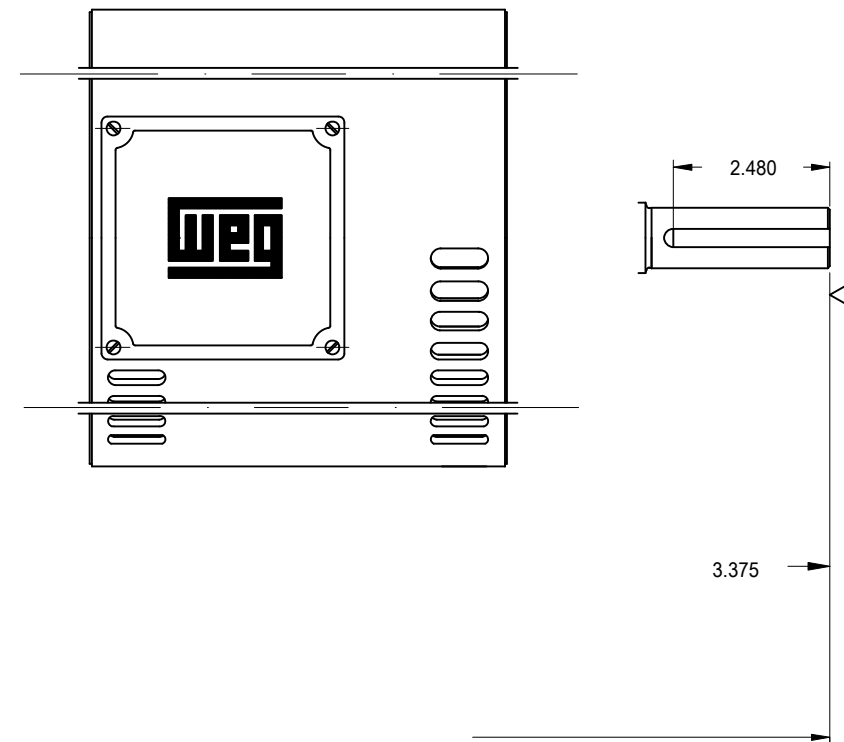
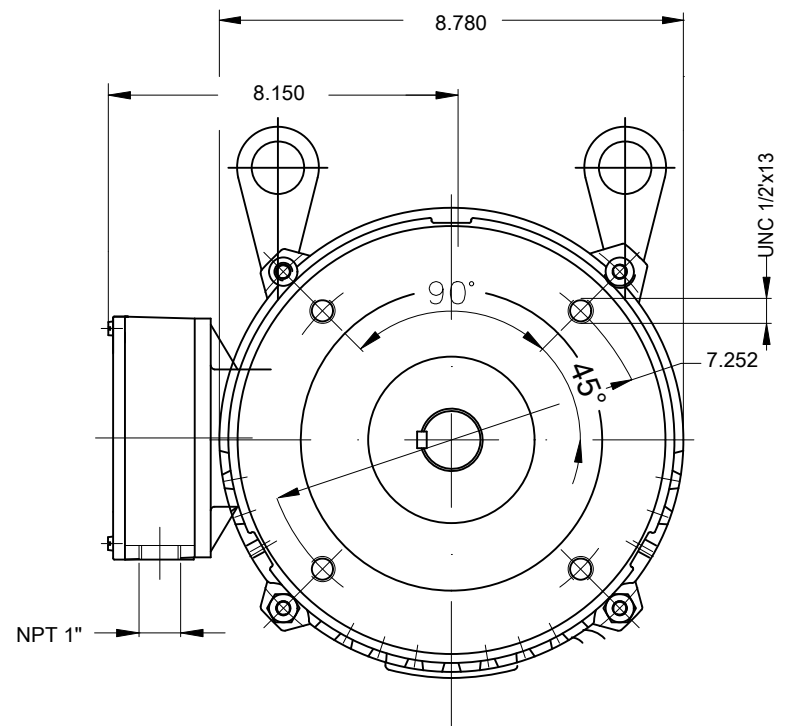

10 HP 02 Poles 60 Hz A

- Packing - crate
- Plastic flat plug
- With drip cover
- Color RAL 5009
- Painting plan 207A
- Mounting B14R(D)

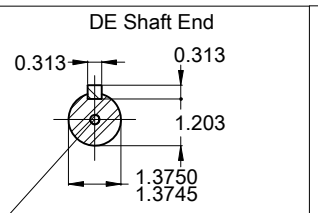

ECM		LOC	SUMMARY OF MODIFICATIONS			HYBRISUSER					00
EXECUTED	HYBRISUSER			THREE PH. MOTOR GENERAL HIGH EFF.			PREVIEW WDD 00				
CHECKED		FRAME 213/5TC IP21 ODP									
RELEASED											
REL. DATE		WMO		Jaragua do Sul	Product Engineering	SHEET	1 / 1				