

DATA SHEET



Three Phase Induction Motor - Squirrel Cage

Customer :						
Product line		: Rolled Steel NEMA Premium Efficiency Three-Phase		Product code :		12845475
Frame	:	213/5TC		Locked rotor time	:	28s (cold) 16s (hot)
Output	:	10 HP (7.5 kW)		Temperature rise	:	80 K
Frequency	:	60 Hz		Duty cycle	:	Cont.(S1)
Rated voltage	:	575 V		Ambient temperature	:	-20°C to +40°C
Poles	:	2		Altitude	:	1000 m.a.s.l.
Rated current	:	9.49 A		Protection degree	:	IP55
	:	7.5x(Code H)		Cooling method	:	IC411 - TEFC
Rated speed	:	3530 rpm		Mounting	:	F-1
Rated torque	:	2.06 kgfm		Rotation ¹	:	Both (CW and CCW)
Insulation class	:	F		Noise level ²	:	70.0 dB(A)
Service factor	:	1.15		Starting method	:	Direct On Line
Moment of inertia (J)	:	0.0303 kgm ²		Approx. weight ³	:	63.8 kg
Design	:	B				
Output	50%	75%	100%	Foundation loads		
Efficiency (%)	89.5	90.2	90.2	Max. traction	:	82 kgf
Power Factor	0.75	0.84	0.88	Max. compression	:	146 kgf
Losses at normative operating points (speed;torque), in percentage of rated output power						
P1 (0,9;1,0)	P2 (0,5;1,0)	P3 (0,25;1,0)	P4 (0,9;0,5)	P5 (0,5;0,5)	P6 (0,5;0,25)	P7 (0,25;0,25)
9.6	7.7	7.5	5.4	3.4	2.5	1.7
			<u>Drive end</u>	<u>Non drive end</u>		
Bearing type	:	6208 ZZ		6206 ZZ		
Sealing	:	V'Ring		Without Bearing Seal		
Lubrication interval	:	-		-		
Lubricant amount	:	-		-		
Lubricant type	:	Mobil Polyrex EM				
Notes						
This revision replaces and cancel the previous one, which must be eliminated. (1) Looking the motor from the shaft end. (2) Measured at 1m and with tolerance of +3dB(A). (3) Approximate weight subject to changes after manufacturing process. (4) At 100% of full load.				These are average values based on tests with sinusoidal power supply, subject to the tolerances stipulated in NEMA MG-1.		
Rev.	Changes Summary			Performed	Checked	Date
Performed by						
Checked by					Page	Revision
Date	12/05/2026				1 / 2	

LOAD PERFORMANCE CURVE

Three Phase Induction Motor - Squirrel Cage



Customer : _____

Product line : Rolled Steel NEMA Premium
Efficiency Three-Phase

Product code : 12845475

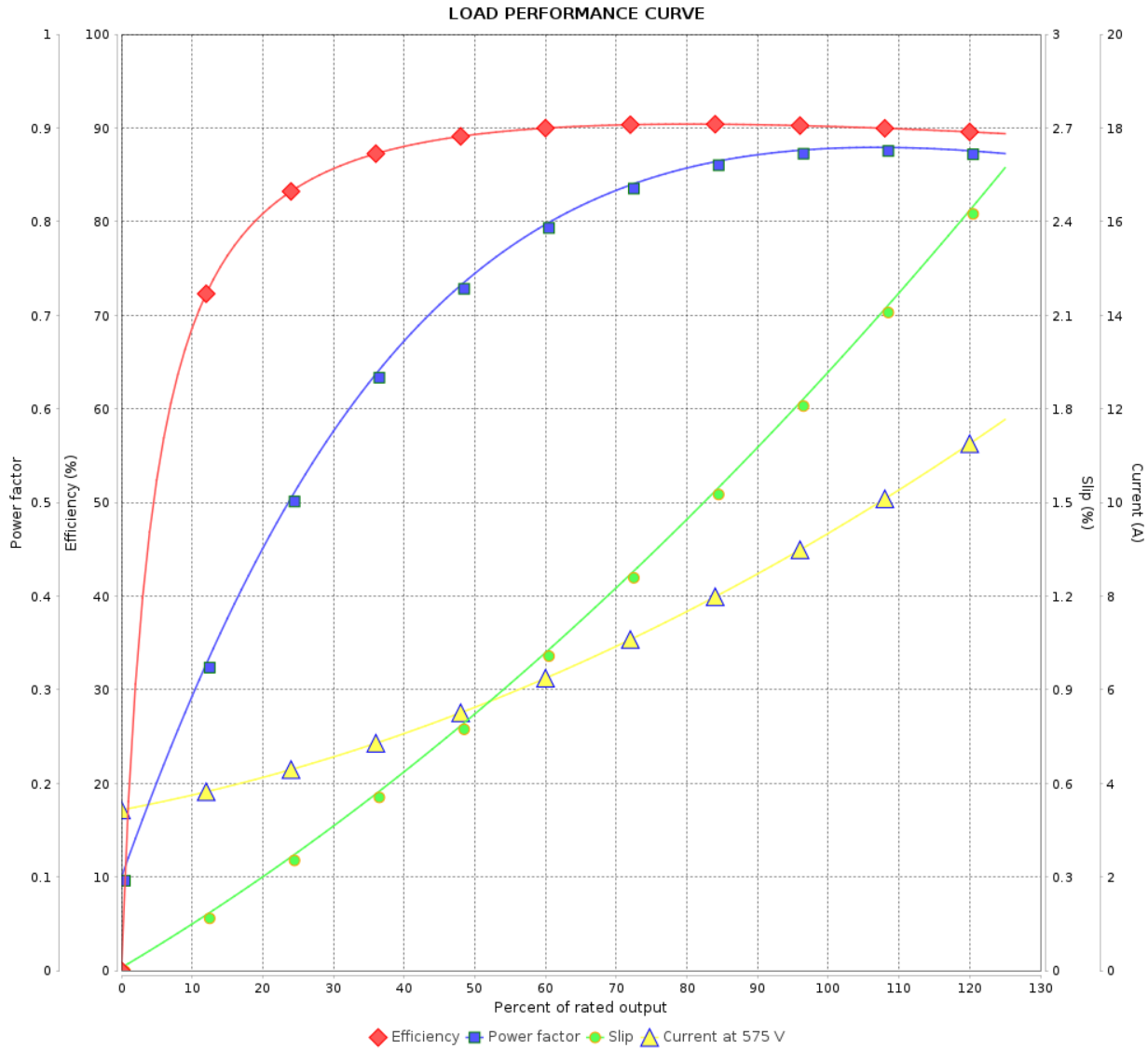

Rev.	Changes Summary	Performed	Checked	Date
Performed by			Page 2 / 2	Revision
Checked by				
Date	12/05/2026			

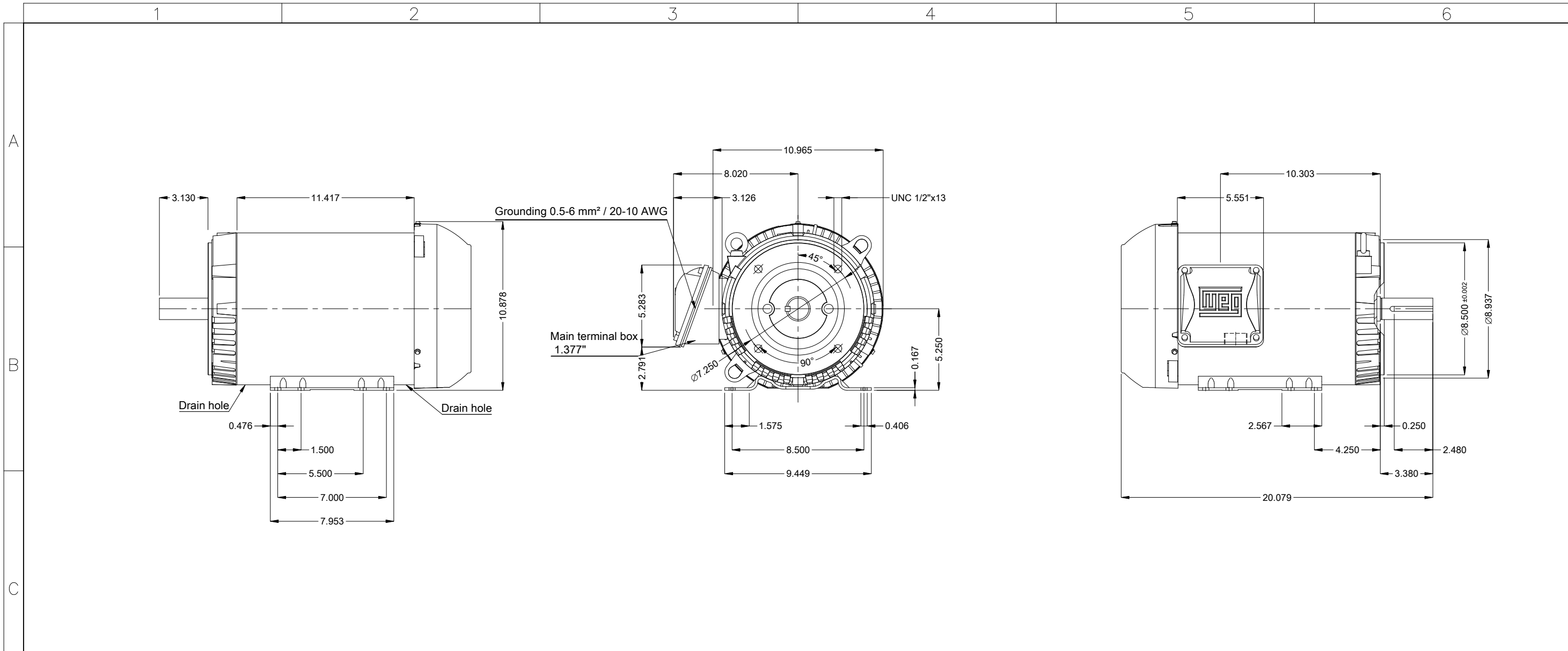

Color Munsell N 1 matte black
 Painting plan 207N
 Mounting MARKET F-1/B34R(D)
 Mounting B34D

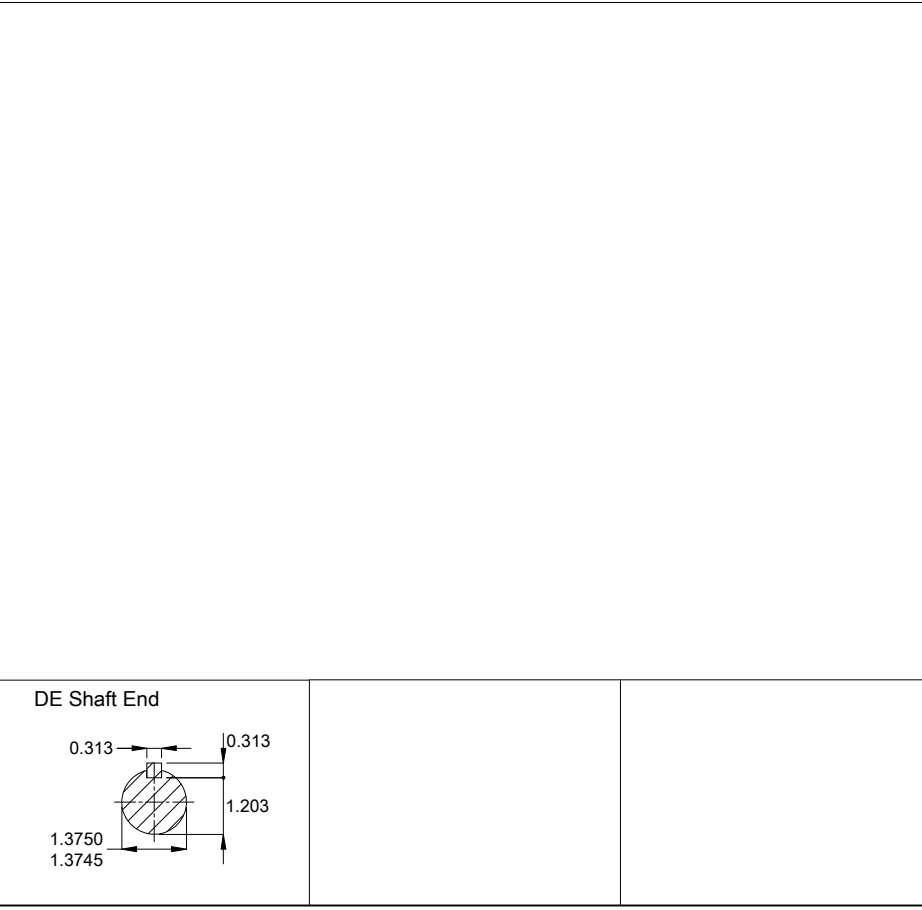

10 HP 02 Poles 60 Hz										A	
Scale 2 : 13											
HYBRISUSER										00	
ECM	LOC	SUMMARY OF MODIFICATIONS					EXECUTED	CHECKED	RELEASED	DATE	VER
EXECUTED	HYBRISUSER	THREE PH. MOTOR ROLLED STEEL NEMA PREM. EFF.					PREVIEW				
CHECKED		FRAME 213/5TC IP55 TEFC					WDD	00			
RELEASED							SHEET	1 / 1			
REL. DATE											